

Who we are

McLaren Doors are the leading manufacturer of PVC overhead roll-up truck and trailer doors.

Our unique design is the lightest in the market and designed to provide superior strength while reducing maintenance!

- Our light weight door will save you gas, and will help to reduce driver injuries!
- Our structural PVC never requires paint and won't show signs of rust!

Contact Us

Located at the corner of Industrial Park S and Vandorf Side road.

420 Industrial Parkway South,
Aurora, On
L4G 3V7

Phone: 877-263-9153

Email: info@mclarendoors.com

Web: www.mclarendoors.com



TOGETHER WE ROLL

McLaren Doors

420 Industrial Parkway South,
Aurora, On
L4G 3V7

Resizing Instructions (2" Streamline bottom panels)



MCLAREN DOORS

A division of Almac Conveyor

Version 1.1

Material List

- 2" Bottom panel 96"Lg
- U-bolts and Brackets x 2 (Wrapped in pull strap)
- Bottom seal (Attached)
- Pull handle (Attached)
- Pull Strap (Attached)
- latch (With 50-005 models only)

Tool Requirement

- Pencil x 1
- Chop saw
- Power Drill with 1/4" drill bit and 7/16" socket
- Dremel or Exacto Knife.
- Rivet gun

Instructions

1. Measure the width of the panel you need to replace.
Note: Panel must be cut evenly from both side.
2. Remove the cables using the 7/16" socket and remove the latch using the 1/4" drill bit.
3. Cut the replacement panel to match the current door width.
4. Mark and cutoff the outer PVC portion of the bottom panel corners to allow for the bracket as shown below:

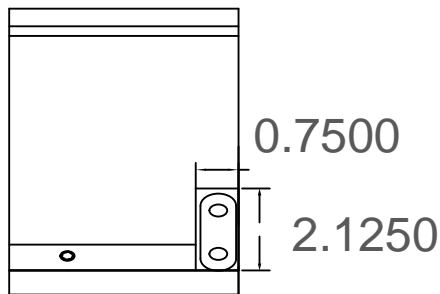

Tip: The measurement should be 0.75" wide and 2.125" high if measuring from the lowest PVC point (not including the flexible seal). For the newer bottom panels, You will also need to cut through the center rib to remove the PVC from the face of the panel.

5. Remove the brackets and rivets that are wrapped in the pull strap.
6. Mark the holes for the U-bolt using the U-bolt plate as a jig.
7. Drill through the panel using the 1/4" drill bit

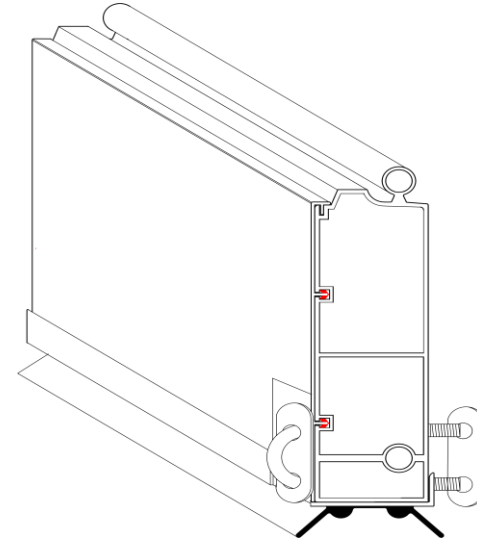

8. Re-attach the cables and U-bolts. (Shown above)
9. Re-install the bottom panel on to the door and put the door back into the tracks.
Note: To download a copy of the McLaren door installation instructions visit us online at www.mclarendoors.com. The instructions are located under the SUPPORT tab.
10. Once you have re-installed the door, put the door in the closed position and place the latch on to the bottom panel.
11. Engage the latch into the door sill to determine the required latch location.
12. Mark the holes and drill out using the 1/4" drill bit.
13. Reattach the latch using 1/4" SS pop rivets (for SS latch use .5", for cast use .75" rivets) to reinstall the latch.

HAVING TROUBLE ?

For any technical support questions please contact www.mclarendoors.com or call us toll free at (877)-263-9153. For afterhours support please contact (416)316-6036.